

**Clutch
Propeller Shaft**

**Repairs and
Maintenance**

Section

Groups

4

Clutch 41

Propeller shaft 45

240, 260

1976-

VOLVO

Content of Manual

Group 41: Clutch

Specifications	1
Special Tools	1
Spare Parts Illustration	2-3
Service Procedures:	
Replacing clutch operating cable	5
Replacing clutch pedal/bushing	5
Removing clutch	5
Clutch facing replacement	5
Servicing pilot bearing	6
Clutch carrier inspection	6
Clutch installation	7
Additional information	7

Group 45: Propeller Shaft

Description	1
Spare Parts Illustrations	2
Service procedures	
Replacing support bearing	4
Propeller shaft	4-5
Re-building U-joints	6-7

NOTE: All references to Model 240 in this manual also apply to DL, GL and GT.

NOTE: All references to Model 260 in this manual also apply to GLE and Coupe.

TP11404/2

3000-3.80

Printed in U.S.A.

Group 41

Clutch

Index

Specifications	1
Special Tools	1
Spare Parts Illustration	2-3
Service Procedures:	
Replacing clutch operating cable	5
Replacing clutch pedal/bushing	5
Removing clutch	5
Clutch facing replacement	5
Servicing pilot bearing	6
Clutch carrier inspection	6
Clutch installation	7
Additional information	7

Specifications

	260 GLE & Coupe	240, DL, GL, GT Diesel
Clutch, type	Single dry plate, diaphragm spring	Single dry plate, diaphragm spring
Size	9"	8½"
Throw-out yoke travel	0 mm 0.00"	3-5 mm 0.12=0.20"

Special Tools

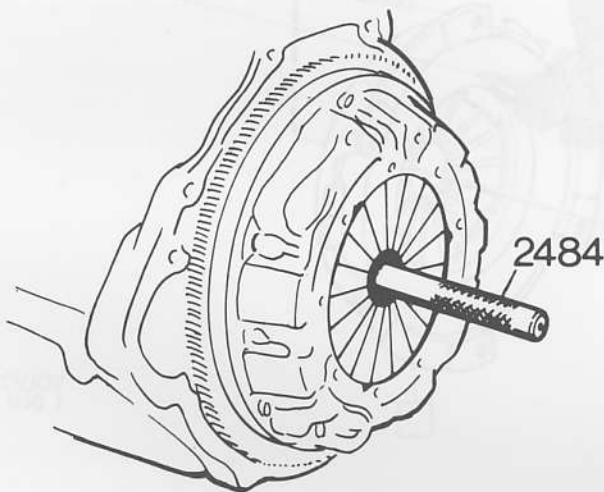

2824 Mandrel

240

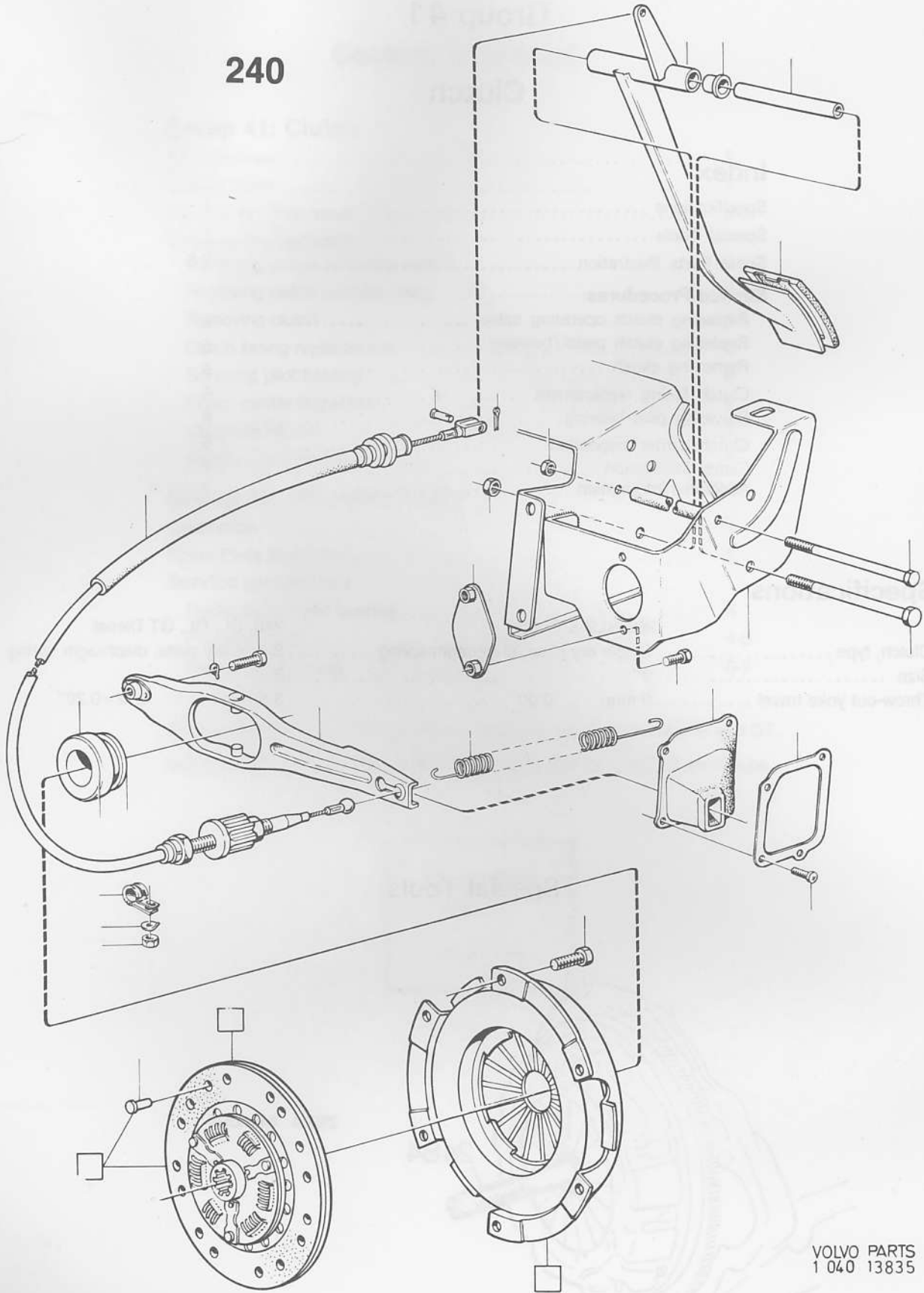

VOLVO PARTS
1 040 13835

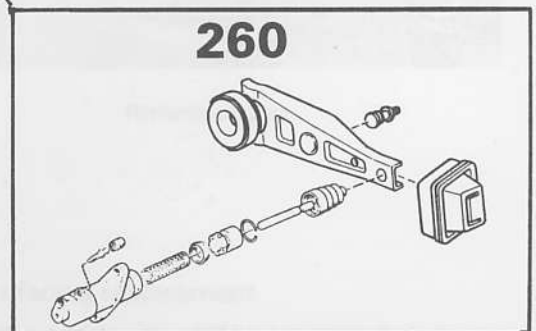
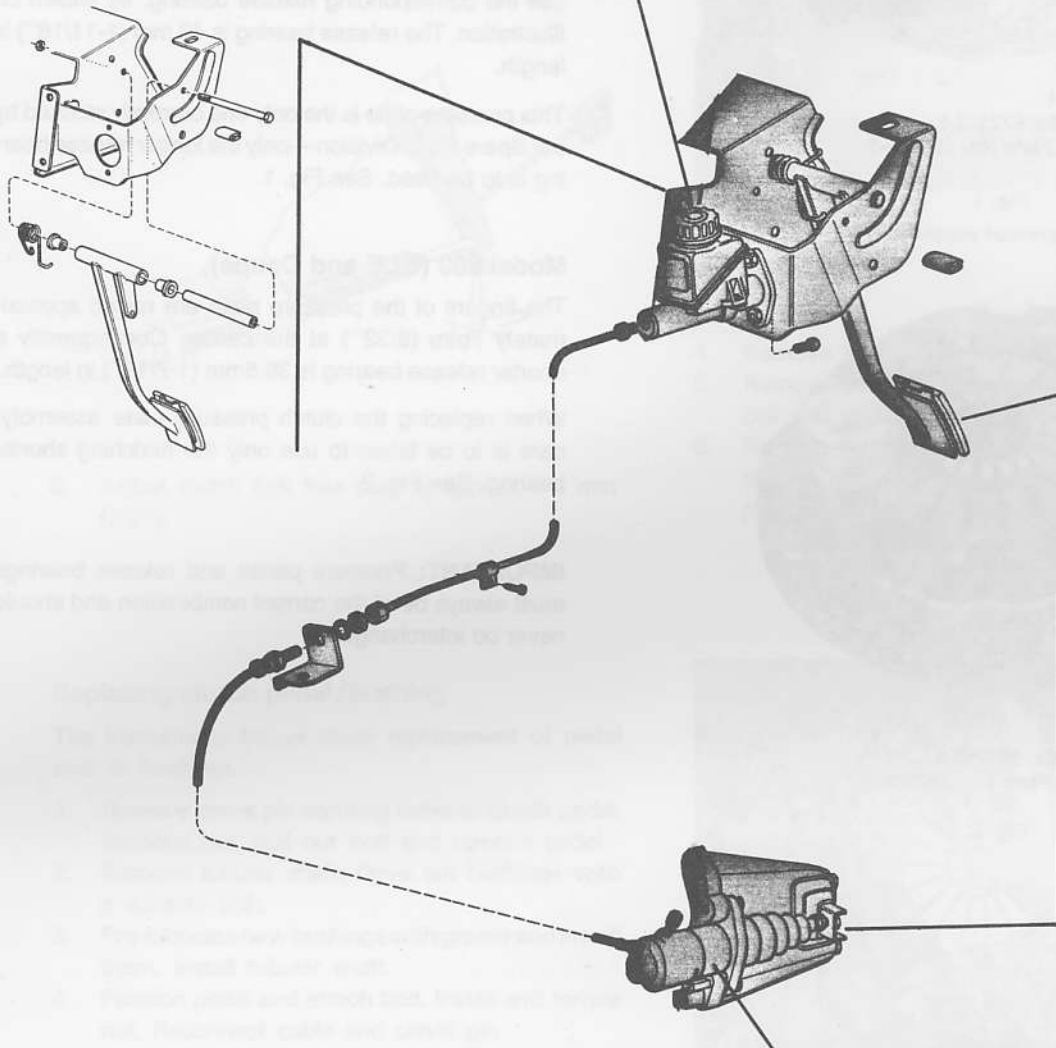
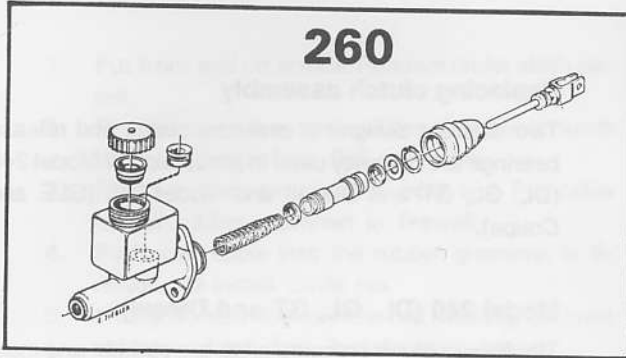

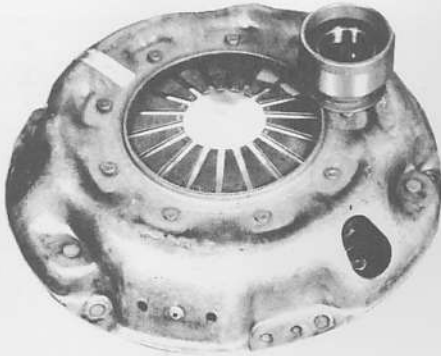

240 Model
Bearing No. 672122-9
Pressure Plate No. 381249-2

Fig. 1

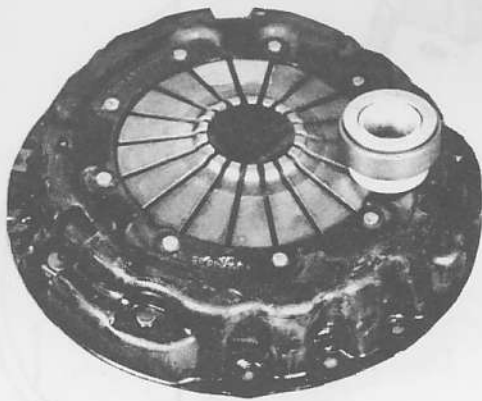

260 Model
Bearing No. 381213-8
Pressure Plate No. 381207-0

Fig. 2

Replacing clutch assembly

Two different designs of pressure plates and release bearings are currently used in production of Model 240 (DL, GL, GT and Diesel) and Model 260 (GLE and Coupe).

Model 240 (DL, GL, GT and Diesel)

The fingers of the pressure plate are straight and must use the corresponding release bearing, as shown on illustration. The release bearing is 43 mm (1-11/16") in length.

This pressure plate is the only one currently stocked by our Spare Parts Division—only the longer release bearing is to be used. See Fig. 1.

Model 260 (GLE and Coupe)

The fingers of the pressure plate are raised approximately 7mm (9/32") at the center. Consequently a shorter release bearing is 36.5mm (1-7/16") in length.

When replacing the clutch pressure plate assembly, care is to be taken to use only the matching shorter bearing. See Fig. 2.

IMPORTANT: Pressure plates and release bearings must always be of the correct combination and should never be interchanged.

Replacing clutch operating cable

1. Put front end on stands. Remove under-dash panel.
2. First remove return spring. Then disconnect clutch cable at clutch fork. Pull out cable.
3. Remove clevis pin at cable upper end. Pull cable out of rubber grommet in firewall.
4. Push new cable into the rubber grommet in firewall. Re-install clevis pin.
5. Fit adjustment device in the bell housing. Connect cable to clutch fork. Install return spring.

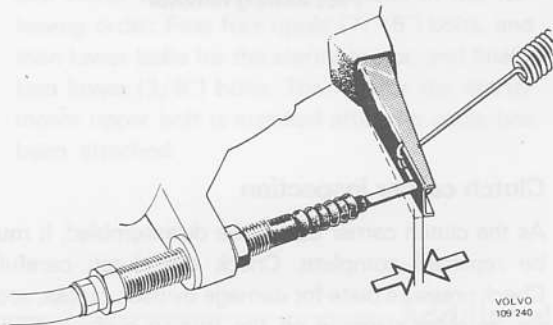

6. Adjust clutch fork free play to approx. 3-5 mm (1/8").

Replacing clutch pedal/bushing

The instructions below cover replacement of pedal and/or bushings.

1. Remove clevis pin securing cable to clutch pedal. Remove nut, pull out bolt and remove pedal.
2. Remove tubular shaft. Drive out bushings with a suitable drift.
3. Pre-lubricate new bushings with grease and install them. Install tubular shaft.
4. Position pedal and attach bolt. Install and torque nut. Reconnect cable and clevis pin.

Removing clutch

Replace clutch disc (clutch)

1. Remove transmission according to instructions.
2. Remove upper bolt for starter motor.

3. Remove release bearing. Disconnect cable from release fork. Slacken cable sheath from bracket.

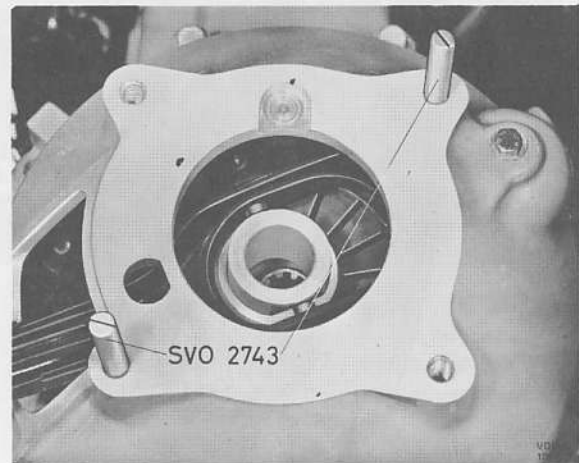

Release bearing

4. Remove bolts. Remove flywheel housing.
5. Remove bolt for release fork ball joint. Remove ball and release fork.
6. Remove bolts holding clutch to flywheel. Loosen them crosswise a couple of turns at a time to prevent warping. Remove clutch and clutch plate.

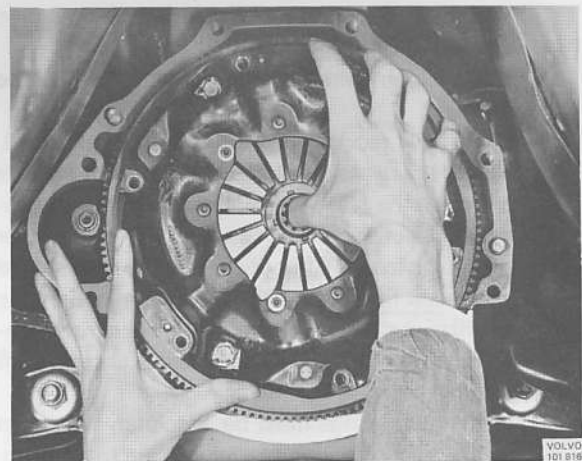

Removing clutch

Clutch facing replacement

1. Drill out rivets with a drill having same diameter as rivets, 3.5 mm (9/64"). Remove old facings.

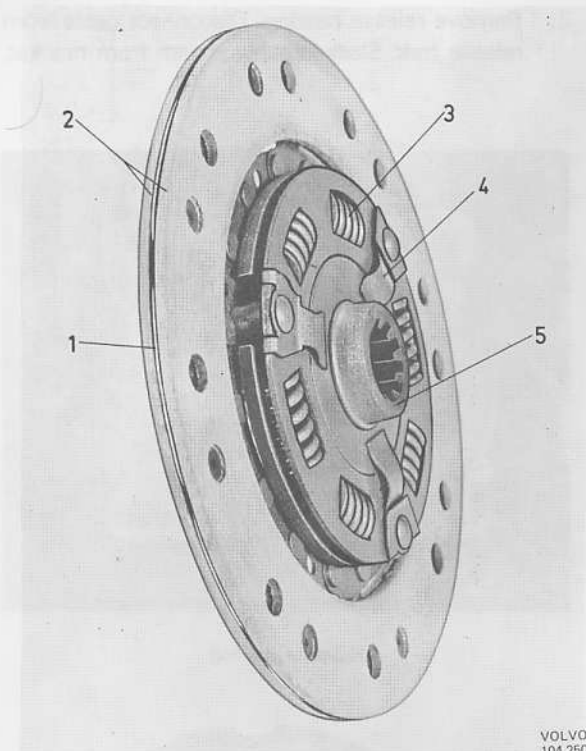

VOLVO
104 250

Clutch disc

- | | |
|------------|-------------------|
| 1. Disc | 4. Damping spring |
| 2. Facings | 5. Hub |
| 3. Spring | |

- Check clutch plate. The indentations on the tongues should be even. The clutch plate must not be warped. The clutch springs and rivets in hub should fit securely and not show any signs of looseness. Check to make sure that there are no cracks.
If the clutch plate has any defects, it should be replaced.
- Rivet new facings (preferably in a rivet press). NOTE: the rivets should be inserted from the side on which the facing lies and riveted from the opposite direction against the disc. Use every other hole in the facing. After riveting, the facings should be spaced from each other as determined by the indentations on the clutch disc. This is most important in order to achieve a smooth engagement when starting and driving.
The clutch facings must be absolutely free from oil. Oil on the facings can cause clutch grabbing.

Servicing clutch shaft pilot bearing

- Use puller hammer to remove pilot bearing. If bearing, after cleaning and light oiling, runs smoothly and evenly and has no noticeable play, it should be packed with ball bearing grease and reinstalled.
NOTE: heat-resistant grease should be used.

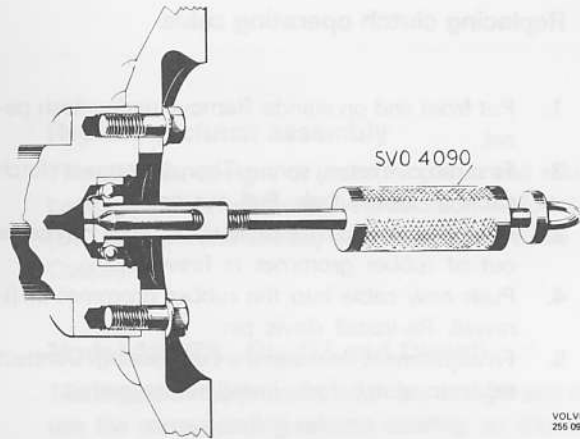

VOLVO
255 09

Pilot bearing removal

Clutch carrier inspection

As the clutch carrier cannot be disassembled, it must be replaced complete. Check the clutch carefully. Check pressure plate for damage by heat, cracks, scoring or other damage on the friction surface. Check the curvature of the pressure plate with a steel ruler, which is placed diagonally across the friction surface of the pressure plate. Then measure the distance between the straight edge of the ruler and the inner diameter of the pressure plate. This measurement must not exceed 0.03 mm (0.00012").

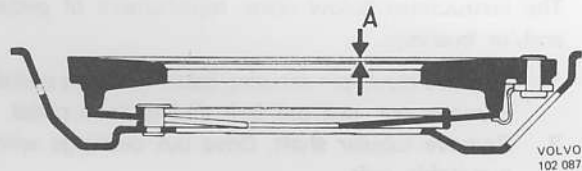

VOLVO
102 087

Checking curvature of pressure plate

There must be no "crowning", i.e. clearance between the straight edge of the ruler and the outer diameter of the pressure plate. Check at several points. Check the pressure spring carefully. If it is cracked or damaged in any way, the clutch should be replaced.
Check the release bearing by turning it a few times under light pressure so that the balls rotate against the races. The bearing should turn easily without binding at any point. The release bearing should also slide easily on the guide sleeve from the transmission.

Clutch installation

Before installation, check that clutch facings, flywheel and pressure plate are completely free from oil. Wash them with gasoline and wipe off with a clean piece of cloth.

1. Set up the clutch plate (the longest side of the hub facing backwards) together with clutch. Insert centering mandrel 2484 as a guide in the pilot bearing in the flywheel.
2. Install six bolts which hold the clutch. Tighten them crosswise a couple of turns at a time. Remove centering mandrel.
3. Install release yoke in flywheel housing.
4. Install upper bolt for starter motor in the housing and install the housing. Install bolts in the following order: First four upper (7/16") bolts, and then lower bolts for the starter motor, and finally two lower (3/8") bolts. The nut for the starter motor upper bolt is installed after the cable has been attached.

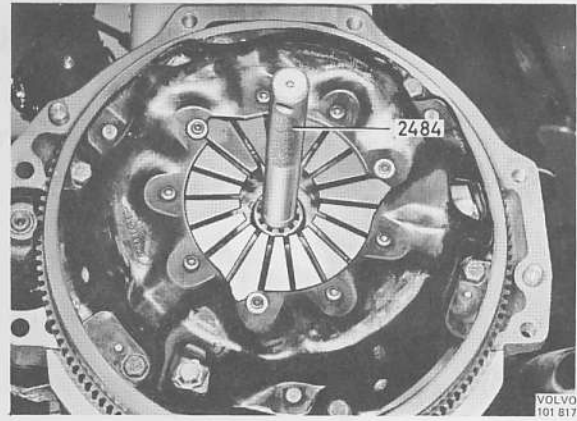

5. Insert cable shaft in bracket and rear nut. Secure cable in release fork. Install release bearing.
6. Install and tighten nut for the upper starter motor bolt.
7. Install the transmission according to instructions.
8. Adjust clutch pedal play.

Additional Information

It is possible to install the rubber washer on clutch cable incorrectly. Such installation will cause the recessed part of the washer to face the wrong direction. This will prevent the steel washer from being located in its seat and will cause the rubber washer to crack and eventually fall off.

As a result of the incorrect installation, the clutch will develop an abnormal slip during declutching operation. Premature failure of the clutch disc may occur.

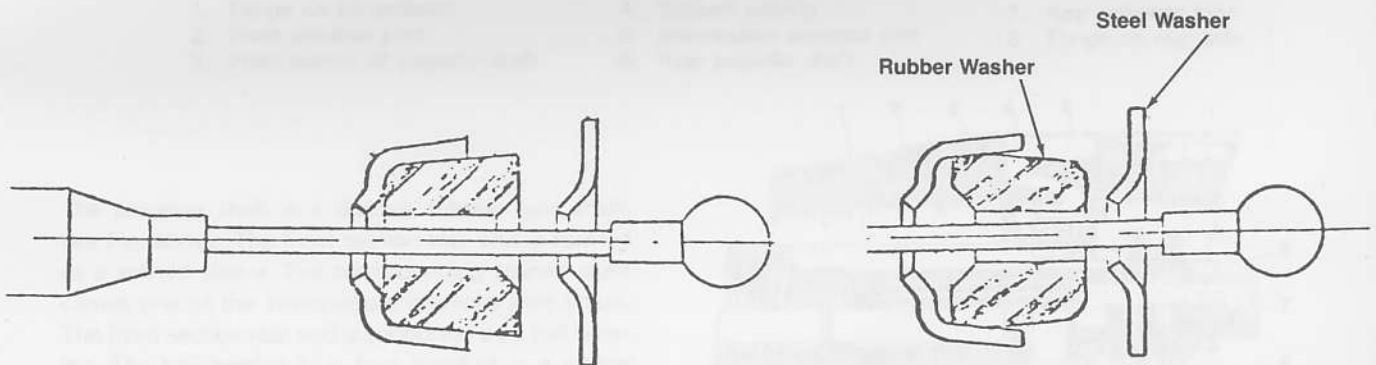

CORRECT

INCORRECT

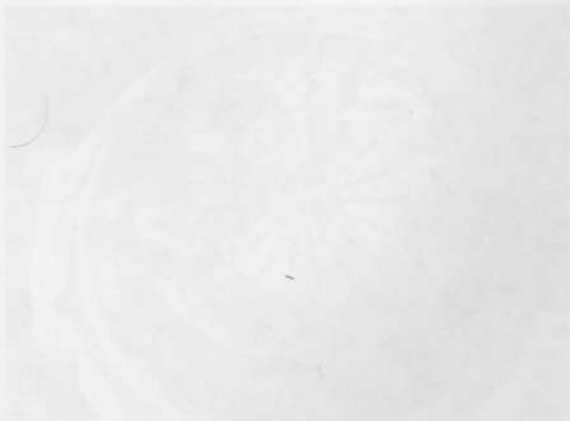

1. The bearing should be mounted on the shaft with the inner ring on the shaft and the outer ring on the housing. The bearing should be mounted on the shaft with the inner ring on the shaft and the outer ring on the housing. The bearing should be mounted on the shaft with the inner ring on the shaft and the outer ring on the housing.

Additional Information

When the bearing is mounted on the shaft, the shaft should be rotated to ensure that the bearing is seated properly. The bearing should be mounted on the shaft with the inner ring on the shaft and the outer ring on the housing. The bearing should be mounted on the shaft with the inner ring on the shaft and the outer ring on the housing.



FIGURE 1

Service check after the bearing

- 1. Use a puller to remove the bearing. The puller should be used to pull the bearing off the shaft. The puller should be used to pull the bearing off the shaft. The puller should be used to pull the bearing off the shaft.
- 2. Check the shaft for wear. The shaft should be checked for wear after the bearing is removed. The shaft should be checked for wear after the bearing is removed. The shaft should be checked for wear after the bearing is removed.

Check installation

- 1. Before you start, check the shaft for wear. The shaft should be checked for wear before you start. The shaft should be checked for wear before you start. The shaft should be checked for wear before you start.
- 2. Install the bearing on the shaft. The bearing should be installed on the shaft. The bearing should be installed on the shaft. The bearing should be installed on the shaft.
- 3. Check the bearing for proper fit. The bearing should be checked for proper fit. The bearing should be checked for proper fit. The bearing should be checked for proper fit.
- 4. Lubricate the bearing. The bearing should be lubricated. The bearing should be lubricated. The bearing should be lubricated.

Additional Information

The bearing should be mounted on the shaft with the inner ring on the shaft and the outer ring on the housing. The bearing should be mounted on the shaft with the inner ring on the shaft and the outer ring on the housing. The bearing should be mounted on the shaft with the inner ring on the shaft and the outer ring on the housing.



There must be no "play" or "looseness" between the shaft and the bearing. The shaft should be checked for wear after the bearing is removed. The shaft should be checked for wear after the bearing is removed. The shaft should be checked for wear after the bearing is removed.

Group 45

Propeller Shaft

Index

Description	1
Spare Parts Illustrations	2
Service Procedures	
Replacing support bearing	4
Propeller shaft	4-5
Re-building U-Joints	6

Description

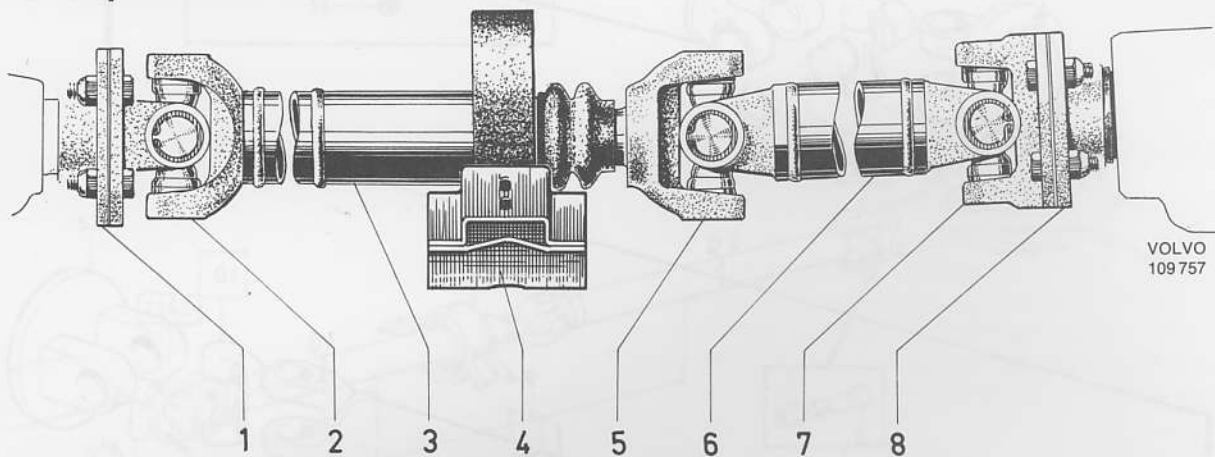

Propeller shaft with support bearing

- | | | |
|-------------------------------------|---------------------------------|-------------------------|
| 1. Flange on transmission | 4. Support bearing | 7. Rear universal joint |
| 2. Front universal joint | 5. Intermediate universal joint | 8. Flange on rear axle |
| 3. Front section of propeller shaft | 6. Rear propeller shaft | |

The propeller shaft is a divided, tubular type shaft, see Fig. above. The front section rear end is formed as a splined sleeve. The corresponding splined shaft carries one of the intermediate universal joint yokes. The front section rear end is supported by a ball bearing. The ball bearing is in turn installed in a rubber bearing housing, which is attached to the propeller shaft tunnel with a cover, see Fig., right. The propeller shaft has three universal joints. Each joint consists of a cross with four trunnions which are carried in flange yokes by needle bearings.

A propeller shaft is paired and balanced as a unit. Front and rear sections are individually marked with a yellow dot and an arrow. The propeller shaft must be replaced only as a paired unit and the front and rear sections have to be installed so that the arrows (the dots) point towards each other.

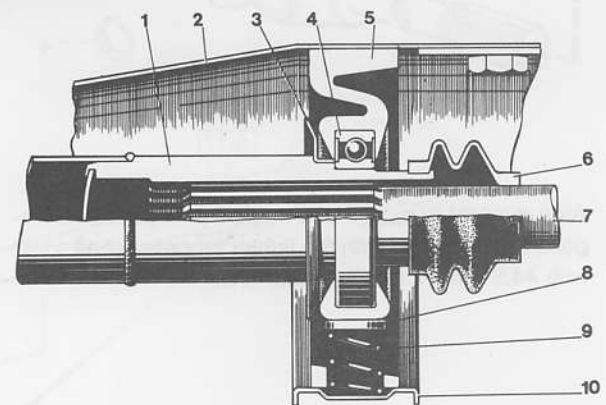

Support bearing

- | | |
|-------------------------------------|------------------------------------|
| 1. Front section of propeller shaft | 7. Nut |
| 2. Floor tunnel | 8. Rear section of propeller shaft |
| 3. Dust cover | 9. Rubber cover |
| 4. Ball bearing | 10. Washer |
| 5. Rubber housing | 11. Suspension spring |
| 6. Dust cover | 12. Cover |

Propeller shafts and parts should be ordered according to type of transmission and type 1140 or 1310 companion flange, and, to a certain extent, the diameter of the tubular shaft.

The center bearing used depends on type of tubular shaft. 1140 has a tube diameter of 44.5 mm = 1.7520" and 1310 a tube diameter of 50.8 mm = 2.000".

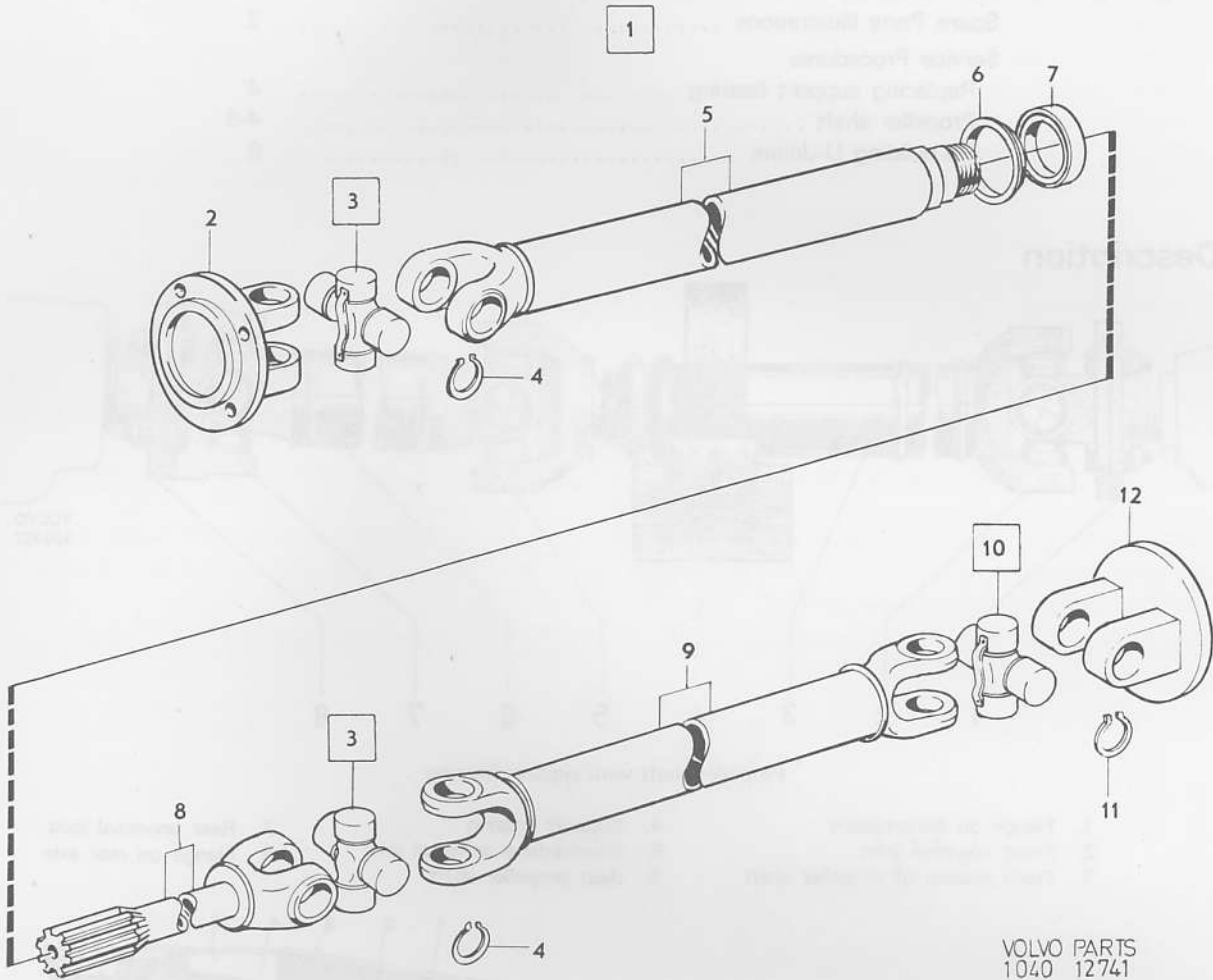

VOLVO PARTS
1040 12741

As a general rule, all 4-cyl. models except station wagons are equipped with the lighter propeller shaft 1140 with 44.5 mm (1.753") tubular shaft.

All station wagon and 6 cyl. models are equipped with the heavy-duty type propeller shaft 1310 with 50.8 mm (2.002") tubular shaft.

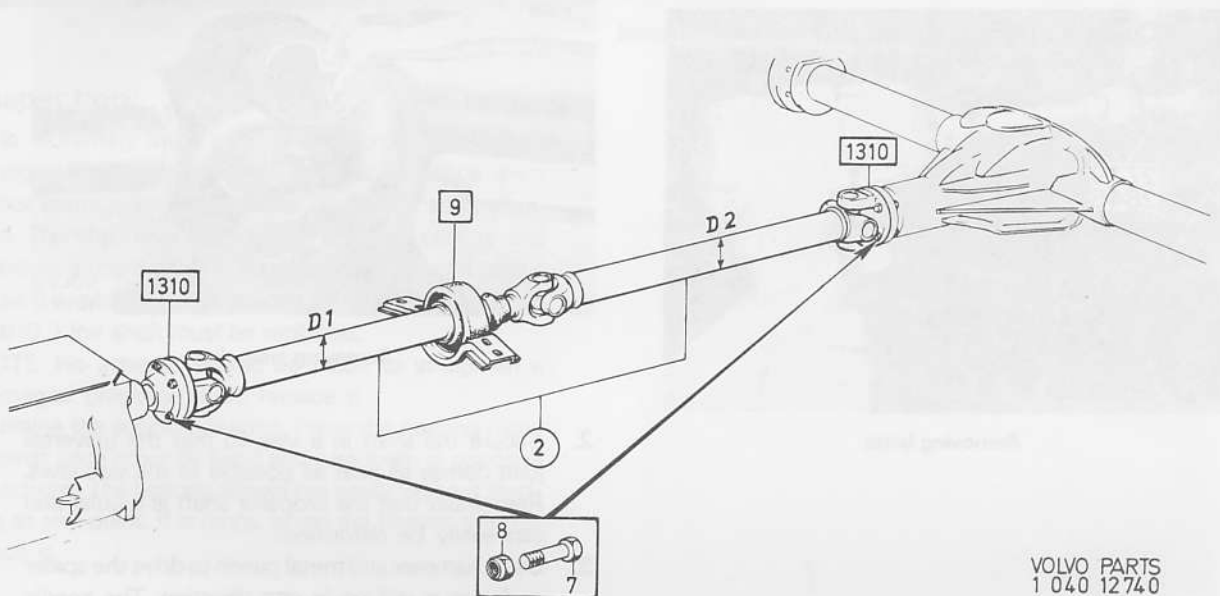
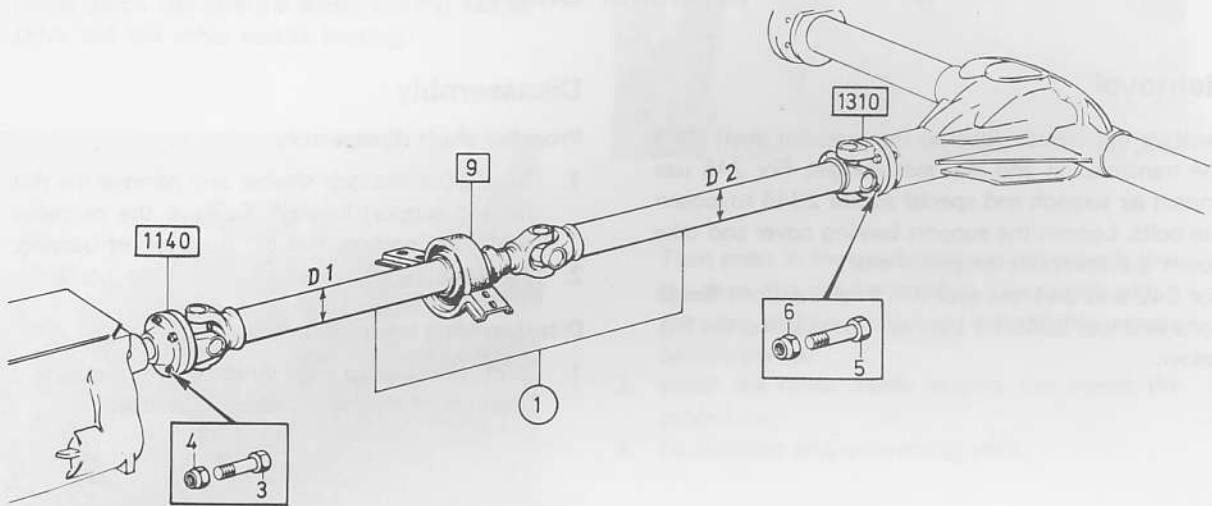
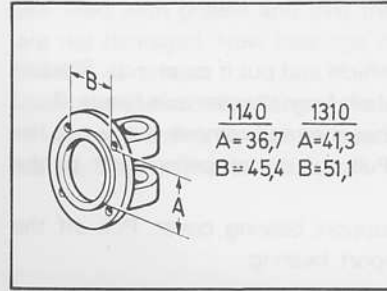
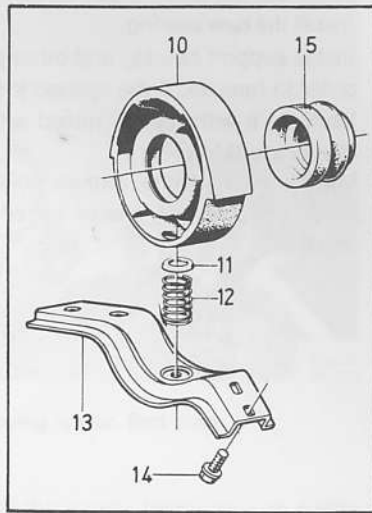

VOLVO PARTS
1 040 12740

Service Procedures

Replacing support bearing

1. Jack up the vehicle and put it on stands. Slacken the propeller shaft from the rear axle flange. Bend back the lock washer and remove the nut at the sliding joint. Pull out the propeller shaft to the rear.
2. Loosen the support bearing cover. Pull off the complete support bearing.
3. Press the old bearing out of the rubber housing. Install the new bearing.
4. Install support bearing and other parts in reverse order to remove. If the splined joint appears dry, lubricate it with grease mixed with molybdenum disulphide (Molykote.)
Make sure that the arrows point toward each other on propeller shafts paired and balanced together.

Propeller Shaft

Removal

Jack up the vehicle. Slacken the propeller shaft from the transmission and rear axle flanges. For 245 use impact air wrench and special socket 2846 to loosen the bolts. Loosen the support bearing cover and take down the complete propeller shaft.

For 242 and 244 use tool 2779 for the front flange bolts and tool 2846 for the rear flange bolts, see Fig. below:

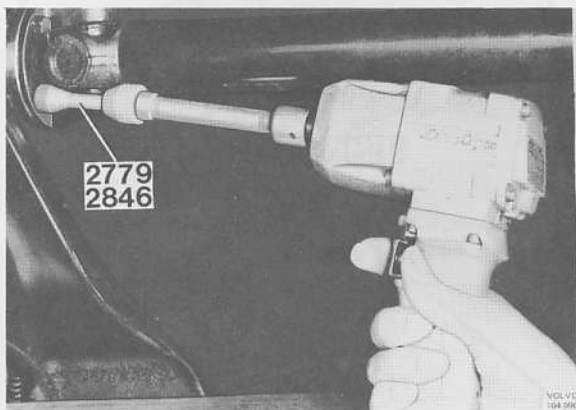

Removing bolts

Disassembly

Propeller shaft disassembly

1. Bend back the lock washer and remove the nut for the support bearing. Remove the propeller shaft rear section. Pull off the support bearing.
2. Take the support bearing out of the housing.

Disassembling universal joints

1. Remove the snap rings which secure the needle bearings in the yokes, see Fig. below:

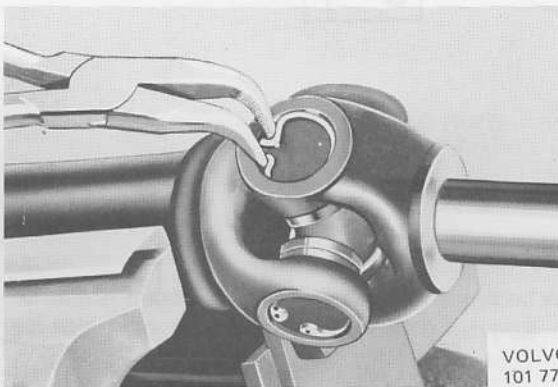

Removing snap ring

2. Secure the shaft in a vise so that the universal joint comes as near as possible to the vise jaws. Remember that the propeller shaft is tubular and can easily be deformed.
3. Use a hammer and metal punch to drive the spider as far as it will go in one direction. The needle bearing will then come about half way out.

- Then drive the spider as far as it will go in the opposite direction, see Fig. below:



Removing spider, first step

- Drive out one of the needle bearings with a thin metal punch. Remove the spider, see Fig. below: Drive out the other needle bearing.

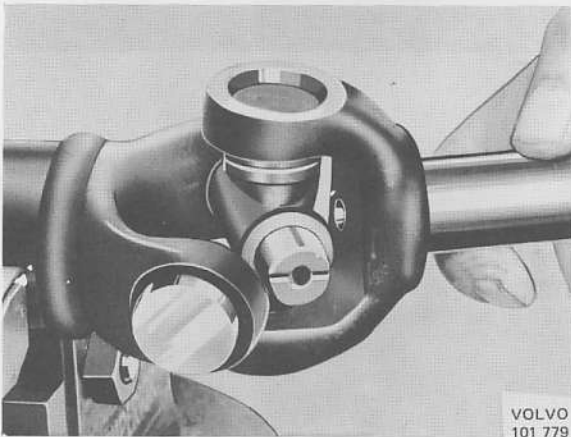

Inspection

It is extremely important that the propeller shaft is straight. The inspection must be careful since even minor damage on the propeller shaft can cause vibration. The shaft should be set up between centers and checked along its entire length with an indicator gauge while it is rotating. If it is out-of-true more than 0.25 mm (0.010") the shaft must be replaced.

NOTE: No attempt should be made to straighten a damaged propeller shaft: replace it.

Examine the support bearing. Press the bearing races against each other by hand and turn them in opposite directions. The bearing should run easily without binding at any point. If it binds, scrap the bearing and replace it.

Assembly

Assembling universal joints

- If old needle bearings are installed, check that they are filled with grease and that the rubber seals are not damaged. New bearings should be half-filled with grease.
- Insert the spider in the flange yoke. Push the spider in one direction so that the needle bearing can be installed in the trunnion, see Fig. below:



Then press in the needle bearing far enough that the snap ring can be installed. Use a drift with a diameter slightly less than that of the needle bearing sleeve.

- Install the other needle bearing and repeat the procedure.
- Do the same on the remaining yoke.

Installation

Installation is in reverse order to removal.

Re-building U-joints

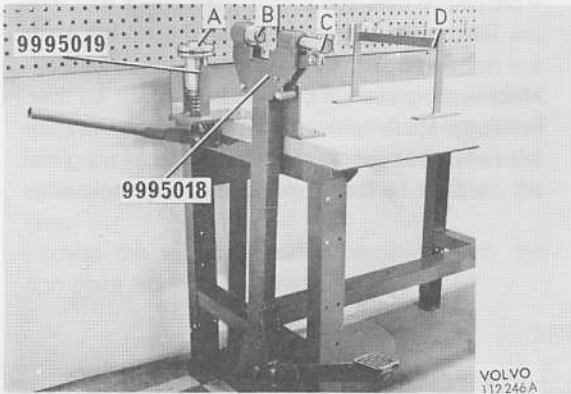

Instructions for press tool 999 5018 and puller 999 5019

- A. Jaws
- B. Arbor
- C. Rod
- D. Support. Part of 999 5018

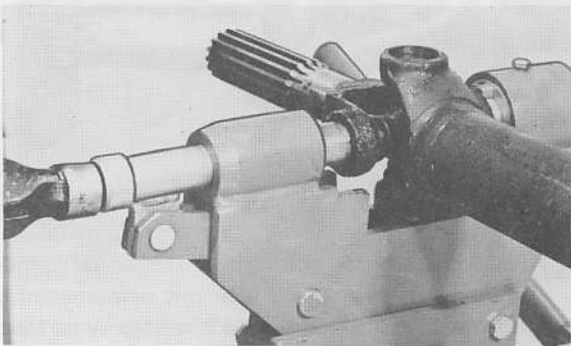

Disassembling universal joint

Remove the lock rings and position the U-joint in the press tool. Use the pedal to move the spider. If the power is not sufficient, use a hammer on the rod.

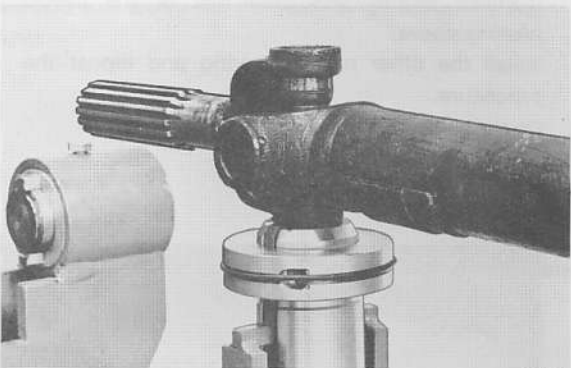

Move the U-joint to the puller. Align the needle bearing between the jaws. Press down the handle which will remove the needle bearing.

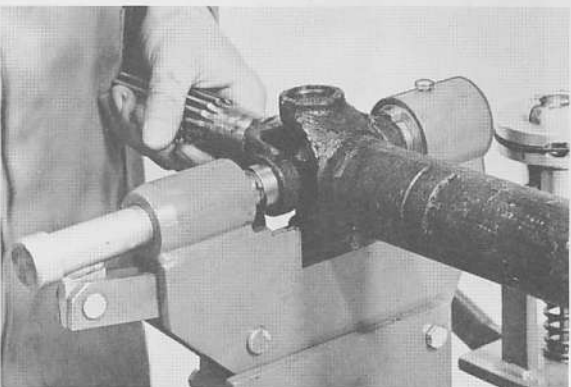

Assembling universal joint

Locate the spider with seals in one of the coupling flanges. Locate one needle bearing. Position the U-joint in the press tool and press in the needle bearing until the lock ring can be installed. Turn the U-joint over and press in the other needle bearing. Install spider and needle bearings in the same way in the other coupling flange. Install the lock rings.

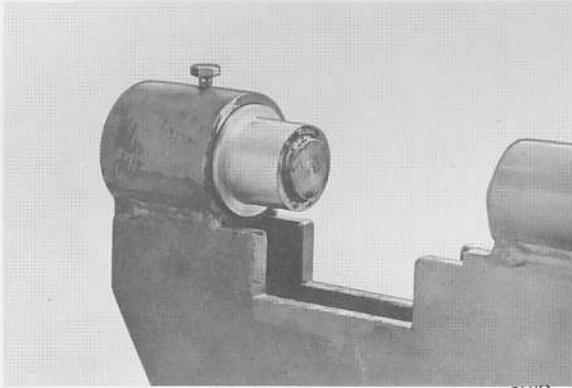

VOLVO
112248A

Replacing press tool arbor

Loosen the screw and remove the arbor. Position the other arbor and tighten the screw.

NOTE: The large arbor has two recesses to be positioned vertically. For this reason it is provided with a hole corresponding with the screw.



VOLVO
112248B

Replacing puller jaws

Remove the O-ring and use a punch to press out the pins.

Jaws for small U-joints

9999 026

Jaws for large U-joints

9999 027

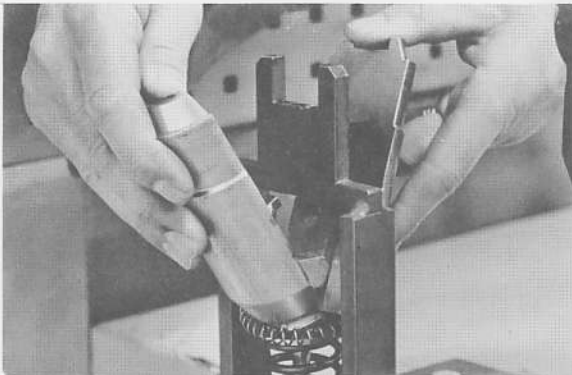

VOLVO
112249B

Lift the ring and bend the jaws aside.



VOLVO
112249A

Hold the lever in the upper position and press the jaws into position. Position the ring with the side marked "up" upwards. Install the pins. Bend the spring, which retains the lower ends of the jaws, into position. Install the O-ring.



**VOLVO SUPPORTS VOLUNTARY
MECHANIC CERTIFICATION
BY THE N.I.A.S.E.**

(U.S.A. Only)

VOLVO

TP11404/2
3000-3.80

Printed in U.S.A.

Printed in U.S.A.